

# P

# PROMOTION

Valid until 31.03.2010

## Terminator-Mill



**Free  
cutter**

**Each insert  
has 8 cutting edges**

**The best of its class!**

See reverse for details of our

**„FREE CUTTER PROMOTION“!!!**

**The height of productivity!**

**ARNO®**  
**WERKZEUGE**

[www.arno.de](http://www.arno.de)

Face milling cutter for  
extreme conditions and  
highest performance.

High-Tech coating and  
accurate insert location  
for excellent results.



# ARNO®-Face milling system

SET Promotion >>

ARNO®-Werkzeuge

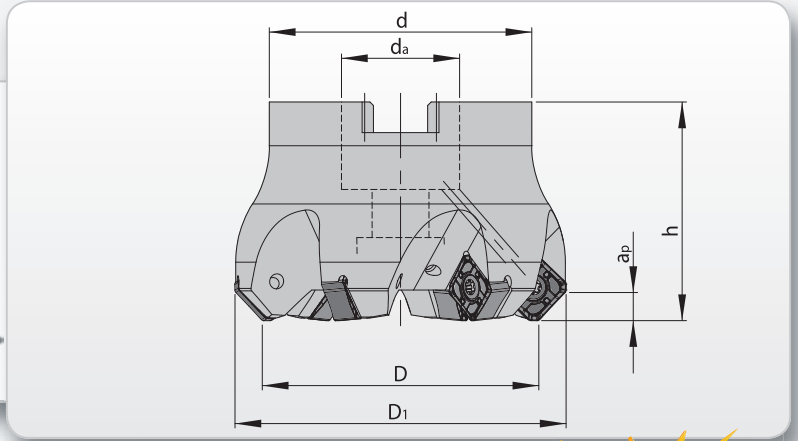

**Free cutter**

## Milling cutter body

Description	D	D <sub>1</sub>	h	d	d <sub>a</sub>	a <sub>p</sub>	Z	Inserts
FTA-145.040.R04-12	40	52,6	50	40	22	6	4	<b>Free cutter with 30</b> -> SNMX 120508 EN-NMS AP2130
FTA-145.050.R05-12	50	62,7	50	48	27	6	5	<b>Free cutter with 40</b> -> SNMX 120508 EN-NMS AP2130
FTA-145.063.R06-12	63	75,8	50	60	27	6	6	<b>Free cutter with 40</b> -> SNMX 120508 EN-NMS AP2130
FTA-145.080.R08-12	80	92,7	50	78	32	6	8	<b>Free cutter with 50</b> -> SNMX 120508 EN-NMS AP2130
FTA-145.100.R10-12	100	112,8	50	90	40	6	10	<b>Free cutter with 50</b> -> SNMX 120508 EN-NMS AP2130
FTA-145.125.R12-12	125	137,8	50	90	40	6	12	<b>Free cutter with 60</b> -> SNMX 120508 EN-NMS AP2130
FTA-145.160.R14-12	160	172,7	60	104	40	6	14	<b>Free cutter with 80</b> -> SNMX 120508 EN-NMS AP2130

## INSERTS Geometry -NMS

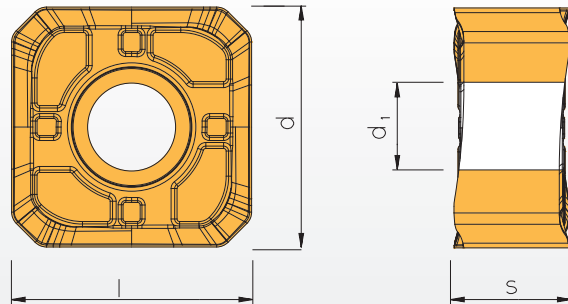

Description	l	d	s	d <sub>1</sub>	r	Grades
						coated
SNMX 120508 EN-NMS	12,0	12,0	5,56	4,4	0,8	AP2130

www.arno.de



**ARNO®**  
WERKZEUGE

Karl-Heinz Arnold GmbH

Karlsbader Str. 4 · D-73760 Ostfildern

Fon +49(0) 711/34 802-0

Fax +49(0) 711/34 802-130

info@arno.de

www.arno.de



**ARNO (UK) Limited** | Unit 3, Sugnall Business Centre | Sugnall, Eccleshall - Staffordshire - ST21 6NF  
☎ +44 01785 850 072 · 📠 +44 01785 850 076 | sales@arno.de · www.arno-tools.co.uk

**ARNO Italia S.r.l** | Via Fiume 13 · 20059 Vimercate (Mi)  
☎ +39 039/68 52 101 · 📠 +39 039/60 83 724 | info@arno-italia.it · www.arno-italia.it

**ARNO Swiss S.A.** | Schanzstraße 1 · CH-8330 Pfäffikon ZH  
☎ +41 449 50 19 88 · 📠 +41 449 19 90 | info@arno-swiss.ch · www.arno-swiss.ch

**ARNO - Rouse USA, LLC.** | 1101 W. Diggins St. · US-60033 Harvard, Illinois  
☎ +1-815-943-4426 · 📠 +1-815-943-7156 | info@arno-rouse.com · www.arno-rouse.com

**ARNO RU Ltd.** | B.Nizhegorodskaya Str.81 · Office 809 · RUS-600000 Vladimir  
☎/📠 +7(4922) 49-04-20 · ☎ +7(920) 928-80-81 | info@amor.ru · www.amor.ru